

# AMBUS<sup>®</sup> ZS / Modem Signal-converter

## Applications

For fast efficient remote reading at a convenient central location in the building or via modem.



## Features

- Built-in power supply for the entire meter network
- Up to 250 meters per AMBUS<sup>®</sup> central unit, with possibilities of extensions
- M-Bus access point via RS232 and RS485 interface for higher-ranking data systems
- Simple M-Bus installation with 4-core cable
- Simple Modem installation

## Your benefits

- Protection of the tenant's private environment
- The remote reading technology guarantees absolute identicalness with local readings
- Read-out by PC/Modem via the normal M-Bus interface to EN 1434-3 at any time
- User-friendly PC software for reading and maintenance services

# Description of the AMBUS® System

## The basic reason for remote readout

New services and tariffs, and the increasing pressure of competition on the energy market call for new techniques for making consumption data easier to interpret.

The rapid development in metering technology has led to a situation where a multitude of data is available on-line for continuous further use.

Bus technology, in particular, enables the consumption data to be constantly recorded.

This enables you to easily establish whether your installation is dimensioned correctly, whether it is set to the optimum operating point, and where there is leeway for improvement.

Periodic checks will help you to increase your service intervals. The causes of malfunctioning can be studied – and sometimes faults removed – remotely, leading to increased efficiency of service work.

Your billing and display software can access the consumption data directly.

The recorded information provides a basis for billing, costing, pricing and for other commercial functions.

By providing personal consultation to your customers, you can gain an edge on your competitors.

The advantages of bus technology in comparison to other technologies:

- meters can be read out at very short intervals
- meters provide a very large volume of data that can be read out as required
- safe and rapid data transmission
- defective meters are immediately recognized
- readout without intrusion on privacy: solution to problems of access and allocation of keys
- standardized interfaces, independent of manufacturer
- real-time recording facilitates integration in automation systems

## M-Bus technology

The increasing use of remote meter readout in consumption data management and automation technology has led the leading meter manufacturers to develop a standardized communication interface - the M-Bus.

This interface is defined in Part 3 of EN 1434. M-Bus meters are now available for almost all flow media. Almost all manufacturers now include M-Bus meters in their product range. In addition, numerous automation systems support the M-Bus protocol.

Manufacturer-independent compatibility is thereby assured. This means that you are not restricted to a single manufacturer's system.

## Technical characteristics

In developing the M-Bus, the special requirements of remote meter readout were taken into account:

- simple, low-cost cabling: for data transmission, a 2 pole unshielded copper cable is sufficient. The cabling can be adapted to suit local conditions independently of particular bus topologies. The network can be several kilometers in length, and can consist of several hundred meters
- low-cost meter hardware: use of an M-Bus interface should not make the meter appreciably more expensive. In consequence, only simple wiring systems, low intelligence and small storage capacity are required
- battery operation: to conserve battery power, the meter interface can be supplied via the bus connection
- safe transmission: a high-performance error handling system ensures that transmission errors are avoided despite simple cabling. As meter readings, and not pulses, are transmitted, interruption of the data cable does not result in metering errors
- data format: the data formats implemented are specially designed for meter readings, measured data and logger data

M-Bus is based on 'master-slave' architecture. In this, each M-Bus network is assigned a unique master, which controls all data communication. The slaves (= meters) only transmit data when they are triggered by the master. System intelligence is quite logically concentrated in the master, while the slaves are kept as lean as possible.

## Typical applications

### Simple and extended network

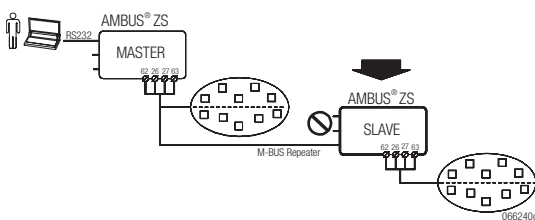
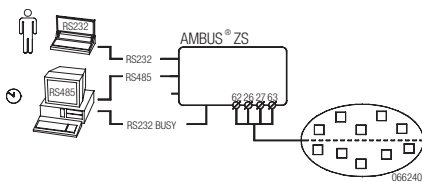
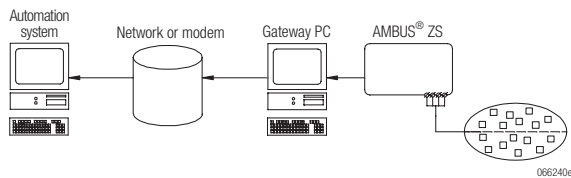
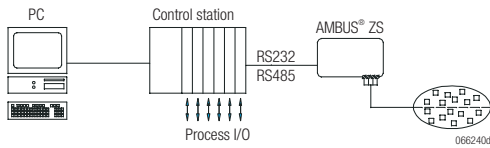
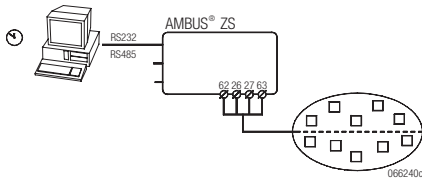
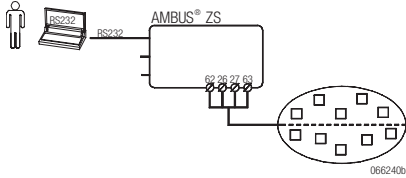
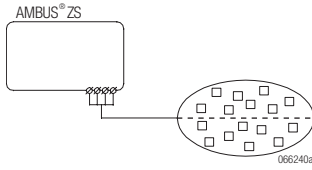

**Manual readout using the intelligent central data unit**  
See new Family AMBUS® Net.

**Mobile recording of meter data**  
Central unit configured as "MASTER"  
Communication: RS-232

**Automatic recording of meter data**  
Central unit configured as "MASTER"  
Communication: RS-232 or RS-485  
The data can be passed on directly to a master system.

**Direct docking to an automation system**  
The meters are integrated in the control system via the bus.  
The central unit is triggered by the control station, and this passes the data to the automation system.

**Docking via gateway**  
A gateway PC records the consumption data and provides these to the automation system.

**Mobile and automated data recording**  
A PC periodically records the consumption data, but the meter remains accessible for servicing and meter reading.  
Communication: RS-232 in combination with RS-485

**Recording of meter data in large networks**  
The M-Bus signal of the master central unit is amplified by a SLAVE central unit.  
Communication: via M-Bus Repeater

## Remote readout via modem

Greater distances can be bridged with the aid of a modem and the public telephone network.

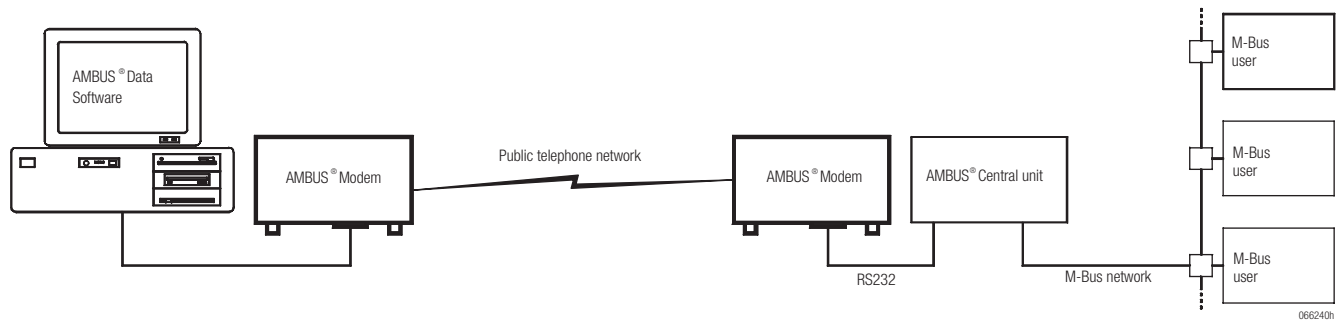

## AMBUS® system

The Aquametro M-Bus product range comprises the AMBUS® system:

- M-Bus compatible water and heat meters
- AMBUS® IS pulse counter
- AMBUS® ZS M-Bus central units
- AMBUS® Data M-Bus readout software
- Installation accessories

Your advantage:

You purchase a turnkey system from a single supplier and gain access to our specialists' extensive knowledge.

### M-Bus meter

The power supply for Aquametro M-Bus meters can be taken from the AMBUS® ZS central unit.

This permits battery-free operation. By avoiding batteries, operating costs can be lowered and the environmental impact reduced. In addition, errors resulting from defective batteries are excluded.

Particularly important: the meters are no longer subject to the restrictions applying to battery operation.

This enables a measurement and computation cycle of only 2 seconds, and also permanent readout, to be realized.

The meters are therefore designed for continuous data recording, which is essential for integration into automation and control systems.

In comparison: a typical measurement interval for battery-powered heat meters is 30 seconds or greater. Also, these meters can only be read out a few times per day.

With M-Bus, meter, billing and instantaneous readings, etc. can be read out.

### M-Bus central units

Most of the M-Bus equipped meters and especially all our Aquametro devices on the actual market can be readout with our Software AMBUS® Data through our AMBUS® ZS units. If necessary, new meters from other manufacturers can be integrated in this system. The selling information "AMBUS® Data drivers" shows you an actual list of compatible meters which AMBUS® Data is able to read out.

All Aquametro M-Bus meters are 100% compatible with EN 1434-3, and can therefore be read out with any M-Bus compatible master.

Furthermore, Aquametro has extensive experience in the integration of meters measuring other media, and in the integration of meters from other manufacturers in the AMBUS® system.

### AMBUS® IS

Using AMBUS® IS, any contact meters without M-Bus interface can be integrated in an AMBUS® system. The AMBUS® IS consists of a free programmable pulse counter that can be triggered via the M-Bus interface.

### AMBUS® central units

AMBUS® central units form the interface between PC or automation system and M-Bus.

They convert the RS-232 data to an M-Bus signal conforming to EN 1434, and power the meters.

### M-Bus accessories

Aquametro electrical accessories will aid you in keeping your cabling and commissioning costs down. The meters can be connected within seconds; the connector system excludes cabling errors that would otherwise be difficult to locate. Detailed instructions on this can be found in the "AMBUS® Planning folder".

## **Software**

AMBUS® Data is an easy-to-use program for readout and management of M-Bus networks.

- Separate meter drivers ensure uninterrupted communication with each meter. They also enable exotic performance features to be selected.
- Using the standardized ODBC interface, other applications such as billing and display programs have direct access to the meter data.
- The modem communication feature is conveniently integrated in AMBUS® Data.
- Using a scheduler, AMBUS® Data can also read out multiple installations at intervals (for example at the billing date, or for recording load profiles).

## **System integration**

Exploit Aquametro's experience to integrate your meters in a master system!

Aquametro meters are at work in numerous installations, and harmonize perfectly with the automation systems of leading manufacturers, such as:

- Landis & Staefa
- Honeywell
- Johnson Controls
- Sauter
- Kieback & Peter
- Renergy
- Siemens S5/S7
- Saia

## **Engineering**

Ensure trouble-free and punctual commissioning by having our experienced service team engineer and install the installation! Particularly for large installations, we recommend you to leave the engineering to our specialists.

## **Maintenance**

The devices do not require any maintenance.

## **Standards and certification**

The appliances are tested according to EN 61010.

They comply with EU requirements and carry the CE mark.

The M-Bus output corresponds to the physical layer as defined in EN 1434-3.

# AMBUS® central units

## General description

Aquametro presents its M-Bus central units in the form of the AMBUS® ZS product range. AMBUS® ZS supplies the meters with power and forms the interface between M-Bus and PC or automation system. It converts the RS-232 or RS-485 signals of the PC or automation system connected to it to an M-Bus signal conforming to EN 1434-3, without however interfering in data transmission, and without recourse to intermediate data storage. The associated PC can access the meters on-line and in real time. In this way, the meters can be interactively read out, operated and parameterized.

Product range:

Remote readout central units	Number of M-Bus appliances	Display/keypad	RS-232	RS-485	M-Bus repeater
AMBUS® ZS 5	approx. 5	—	•	—	—
AMBUS® ZS 60	approx. 60	—	•	•	•
AMBUS® ZS 250	approx. 250	—	•	•	•

## Block diagram

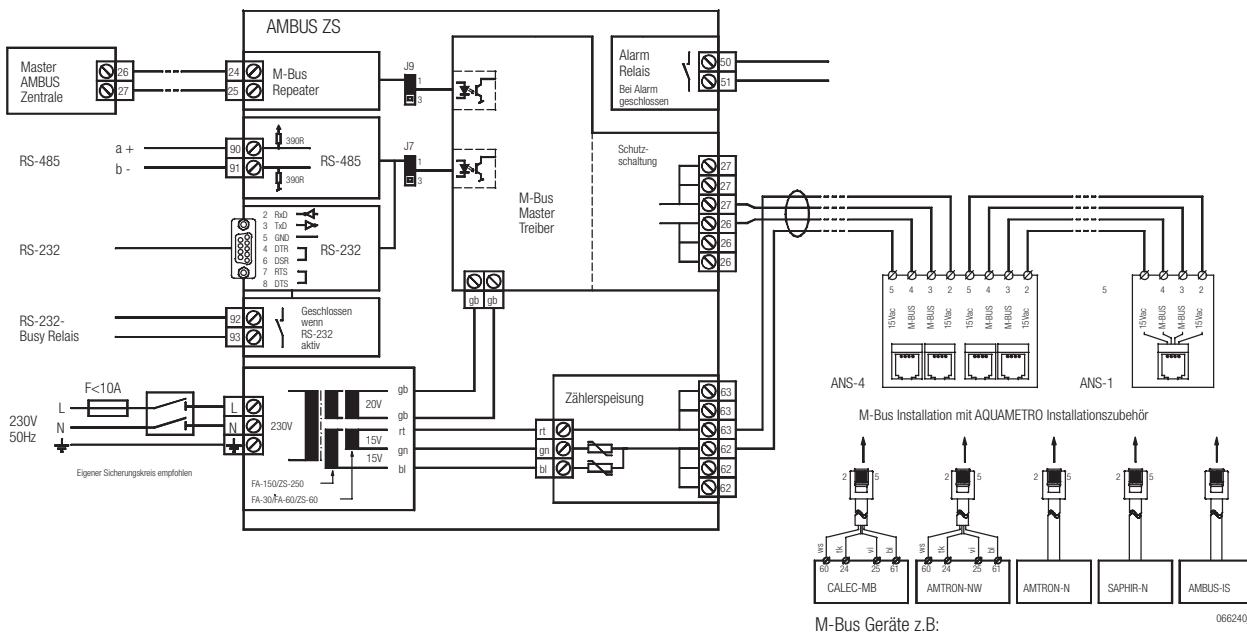

## Busy:

This signal permits to know the RS-485-Master that the Master wired to the RS-232 is requesting meter dates through the M-Bus and thereby has to stop his communication.

## AMBUS® ZS 5



Die AMBUS® ZS 5 is a low-price and extremely compact central unit for small M-Bus networks. It is particularly suitable for small installations and laboratory and software testing. It can power up meters.

### Limitations compared to AMBUS® ZS 60/250

- no RS-485 interface, and therefore no busy relay
- no M-Bus Repeater input
- only a single M-Bus circuit available
- small-size plastic IP 42 housing (optionally IP 54)

### Technical data

AMBUS®	ZS 5
Number of meters (type)	20*) M-Bus-slaves
RS-232	•
RS-485	—
M-Bus-Repeater	—
Transmission rate	300, 2400, 9600 baud
Meter supply*)	15 V AC ± 20% 300 mA
Power supply	230 V AC +10%, -15%, 50 Hz
Max. load	8 VA
Ambient temperature	0...50°C
Protection	IP42
Dimensions	129x87x50 mm

\*) The exact number of meters that may be connected can be calculated based on the supply current available and the current capacity of the individual meters.

### Dimensional sketches

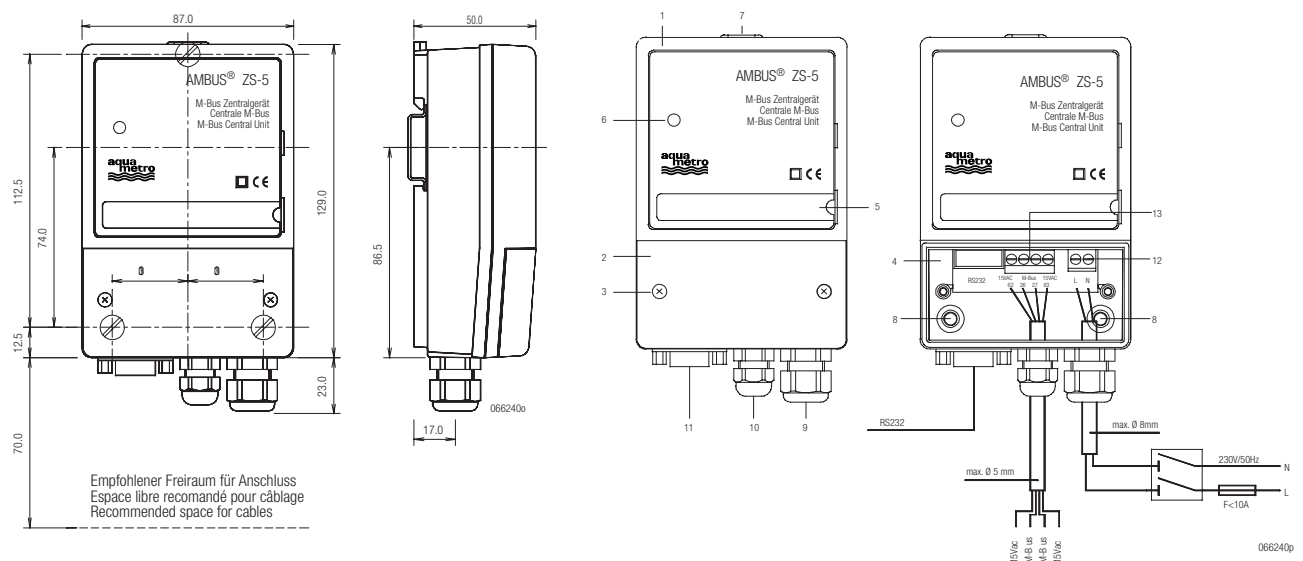

### Legende

- |                     |   |
|---------------------|---|
| 1 Housing cover     | 8 Opening for fixing screw                  |
| 2 Terminal cover    | 9 Cable gland for network connection        |
| 3 Cover screws      | 10 Cable gland for bus cable                |
| 4 Terminal box      | 11 9 pin D-Sub socket for RS-232 connection |
| 5 Clip-on plate     | 12 Mains connection                         |
| 6 Operating display | 13 Bus connection                           |
| 7 Mounting          |   |

## AMBUS® ZS 60 / 250



AMBUS® ZS consists of two functional blocks: a low-voltage supply and a bi-directional M-Bus converter with three communication channels (RS-232, RS-485 and M-Bus Repeater).

### Interfaces

AMBUS® ZS permits access to the M-Bus via three interfaces:

- the RS-232 interface is the most commonly used interface. It is fitted with a 9 pin D-Sub socket, and can be connected to a free COM port of a PC via standard modem cable
- up to 16 central units can be routed via the RS-485 interface, for example to an automation system. At the same time, the RS-232 interface can continue to be used for local or modem readout
- the M-Bus Repeater input can be used to amplify the M-Bus signal of another central unit, for example when data must be transmitted over greater distances, or when more than 250 meters must be connected

### Technical data

AMBUS®	ZS 60	ZS 250
Number of meters (type)	60*)	250*)
RS-232	•	•
RS-485	•	•
M-Bus-Repeater	•	•
Transmission rate	300, 2400, 9600 baud	300, 2400, 9600 baud
Meter supply*)	15 V AC ± 20% 1.3 A	15 V AC ± 20% 5 A
Power supply	230 V AC +10%, -15%, 50 Hz	230 V AC +10%, -15%, 50 Hz
Max. load	50 VA	110 VA
Ambient temperature	0...55°C	0...55°C
Protection	IP54	IP54
Dimensions	160x240x54	160x240x54

\*) The exact number of meters that may be connected can be calculated based on the supply current available and the current capacity of the individual meters.

### Priority control

The M-Bus master-slave architecture does not permit the bus to be controlled simultaneously by several appliances.

The cleverly devised priority control system does, however, permit an M-Bus network to be triggered via different channels of the central unit.

Thus using a laptop, the service technician or meter reading service can read out a central unit connected to an automation system by means of an RS-485 interface via the RS-232 interface.

The RS-232 interface has highest priority to enable the technician to access the network without unnecessary delay, even when the automation system is in continuous readout mode.

During operation of the RS-232 interface, one of the relay contacts is closed (busy).

This contact can be used either to inform the automation system that readout is not possible at the present time, or to interrupt the line to the RS-485 interface or the M-Bus Repeater.

Notes:

As with other appliances, the Aquametro central units do not support simultaneous readout via multiple channels.

When the central unit is connected to an automatic readout system, and there is a likelihood that the bus could also be accessed via the RS-232 interface, a busy signal must be generated to ensure the readout system recognizes that readout is temporarily disabled.

### M-Bus outputs and low-voltage supply

The network output consists of two M-Bus and two supply cables (four wires).

In total, there are three outputs, each corresponding to a four wire cable.

The output low-voltage supply is 15 V AC.

The outputs are short-circuit protected.

### Notes for mounting

Laying of cable in raceway.

If the cables are laid in a 40 mm high raceway (A), access to the RS232 interface (B) is still assured.

## Dimensional sketches

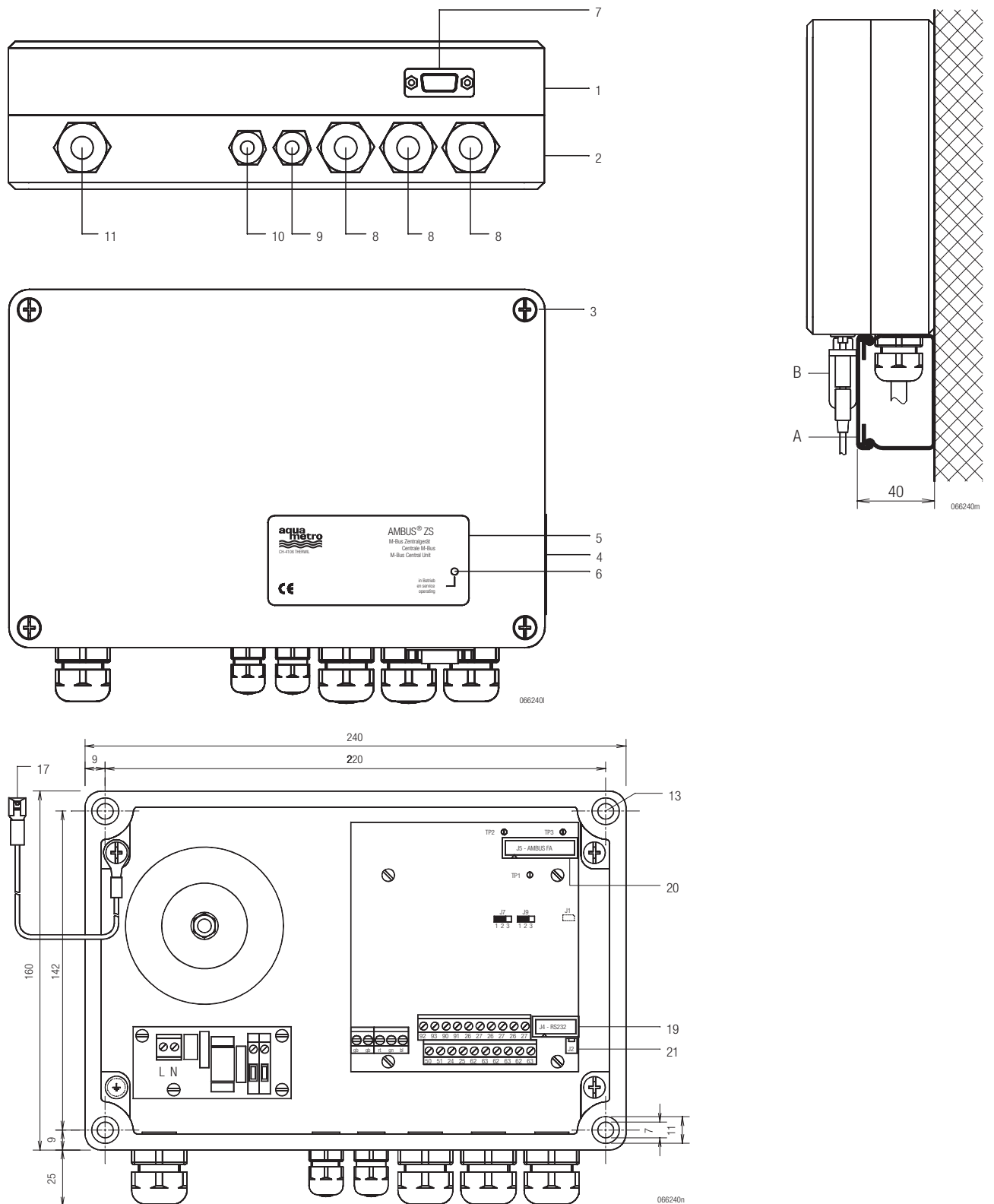

### Legende

- |  |  |
|--|--|
| 1 Housing cover                            | 9 Cable gland for M-Bus Repeater / RS-485 connection |
| 2 Housing base                             | 10 Cable gland for relay                             |
| 3 Housing screws                           | 11 Cable gland for network connection                |
| 4 Name plate                               | 13 Mounting holes                                    |
| 5 Front decal                              | 17 Ground wire for the housing cover                 |
| 6 Operating display                        | 19 Plug D-Sub jack                                   |
| 7 9 pin D-Sub socket for RS-232 connection | 20 Plug for display board                            |
| 8 Cable gland for 1 M-Bus circuit          | 21 Plug for operating display                        |

# AMBUS® Modem

## M-Bus protocol and modem operation



- automated remote readout of multiple installations with AMBUS® Data and scheduler
- precise readout at billing date
- operation monitoring
- periodic checking of meters
- remote diagnostics for system errors

To ensure high-performance error handling, the EN 1434 M-Bus protocol places stringent requirements on the entire data transmission path. Most commercial modems do not comply with these requirements, and this has prompted Aquametro to develop a special M-Bus modem. The EN 1434 M-Bus protocol specifies the following:

- Word length. For error handling, the start, stop and parity bits must be transmitted. For this, the modem must transmit 11 bit instead of the usual 10 bit.
- Timing. No delays are permitted in the transmission path. With most modems, interruption of transmission occurs during data compression and error handling that is outside the limits specified in the standard. To avoid this, the baud rate of the modem must equal that of the M-Bus.

### Notes

These requirements apply to the entire transmission path. Thus for modem operation, both PC and M-Bus modems must be compatible with M-Bus.

### Description

The AMBUS® Modem was specially developed for M-Bus operation under heavy field conditions. It is preconfigured and complying with AMBUS® Data. All wiring cables are delivered with the modem.

### Technical data

For further information please contact our sales office.

# Dimensioning

## Dimension tables

The following rules of thumb will aid you in dimensioning your network:

1. Determine the sum of the mains-connected load units based on the following power consumption table:

Meters	M-Bus load unit	Supply load unit	
		from central unit	local supply <sup>*)</sup>
SAPHIR N	1	1	—
AMTRON® N	1	1.1	—
AMTRON® NW	1	1.6	0
CALEC® MB	1	4	0
CALEC® light	1	3	0
AMBUS® IS	1	1.3	—
Battery Counter + AMTRON® E/C/S, SAPHIR E / AMBUS® IS2	1	—	0

<sup>\*)</sup> The meters that are not supplied via the bus but, for example, via the 230 V connection, place no demand on the bus supply, and must not therefore be counted.

2. Select correct central unit based on the following load table:

AMBUS® central units	M-Bus load unit	Supply load unit
ZS 5	20	5
ZS 60	60	60
ZS 250	250	250

3. Determine cable type using the following formula:

$$\Delta U = LE \times KK \times L, \text{ where}$$

$\Delta U$  = voltage drop. This must not exceed 5 V!

$LE$  = sum of load units

$KK$  = cable constant,

= 1.35 for 0.8 mm<sup>2</sup> line cross-section

= 0.47 for 1.5 mm<sup>2</sup> line cross-section

= 0.29 for 2.5 mm<sup>2</sup> line cross-section

$L$  = cable length between central unit and most remote meter (in 1000 m units)

Tips:

This formula has been heavily simplified to aid in roughly dimensioning the cabling. It is based on the worst case. For large installations, it is often worthwhile to calculate the voltage drops as a function of the given network structure.

Detailed instructions on this can be found in the AMBUS® planning folder.

Larger networks should always be designed by a specialist.

In the case of large development projects, it is advisable to consult the Aquametro technical sales support at an early stage to ensure efficient and effective engineering and realization.

## Wiring diagrams/terminal configuration

<b>AMBUS® connections</b>	<b>ZS 5</b>	<b>ZS 60 / 250</b>	<b>Modem</b>
230 V phase/neutral/ground	L/N/-	L/N/PE	L/N/PE
M-Bus output	26/27	26/27 (3x)	—
Meter supply	62/63	62/63 (3x)	—
M-Bus-Repeater	—	24/25	—
RS-232	D-Sub9 jack	D-Sub9 jack	D-Sub9 jack
RS-485 A+/A-	—	90/91	—
Alarm relay	—	-	—
RS-232 busy	—	92/93	—
Test pins			
Transmission signal in direction M-Bus (TXD)	—	TP1	—
Receiver signal in direction M-Bus (RXD)	—	TP2	—
Ground	—	TP3	—
Jumper			
RS-232/RS-485 enabled	—	J7: 1-2 closed	—
RS-232/RS-485 disabled	—	J7: 2-3 closed	—
M-Bus-Repeater enabled	—	J9: 1-2 closed	—
M-Bus-Repeater disabled	—	J9: 2-3 closed	—

## Ordering data

<b>Meters</b>	<b>Ordering No.</b>
<b>M-Bus converter</b>	
AMBUS® ZS-5	93542
AMBUS® ZS-60	93538
AMBUS® ZS-250	93537
Upgrade to IP54 protection for AMBUS® ZS-5	81581
<b>Modem</b>	
AMBUS® Modem Eurocom24-PC	92431
AMBUS® Modem Eurocom24 AMBUS® central unit	92432
<b>Software</b>	
AMBUS® Data Demo-Version	80007
AMBUS® Data License 5 meters	80012
AMBUS® Data license 15 meters	80170
AMBUS® Data license 30 meters	80171
AMBUS® Data license 60 meters	80008
AMBUS® Data license 100 meters	80172
AMBUS® Data license 150 meters	80173
AMBUS® Data license 250 meters	80009
AMBUS® Data open license	80010
UPDATE drivers for M-Bus meters	80011
<b>Accessories</b>	
ANS-1/AP M-Bus connection box	80006
AMBUS® ANS-1 RJ11	81585
RJ11 cable single-sided, length 1,5M	81588
RJ11 cable double-sided length 1,5m	81589
ANS-4 AP Distributor on wall, sealable	81643
ANS-4 DIN Distributor for DIN rail	81644

### AQUAMETRO AG

Ringstrasse 75  
CH-4106 Therwil  
Phone 061 725 11 22  
Fax 061 725 15 95  
info@aquametro.com

### AQUAMETRO SA

Rue du Jura 10  
CH-1800 Vevey  
Phone 021 923 51 30  
Fax 021 922 58 44  
info@aquametro.com

### AQUAMETRO MESSTECHNIK GmbH

Zum Panrepel 24  
D-28307 Bremen  
Phone 0421 / 871 64-0  
Fax 0421 / 871 64-19  
info.amd@aquametro.com

### AQUAMETRO BELGIUM SPRL

Bd. Lambertmont 131  
B-1030 Bruxelles  
Phone 02 / 241 62 01  
Fax 02 / 216 22 63  
info.amb@aquametro.com

### AQUAMETRO s.r.o.

Prosecká 811 / 76a  
CZ-190 00 Praha 9  
Phone 02 / 86 88 77 78  
Fax 02 / 86 88 95 59  
info.amc@aquametro.com



www.aquametro.com